

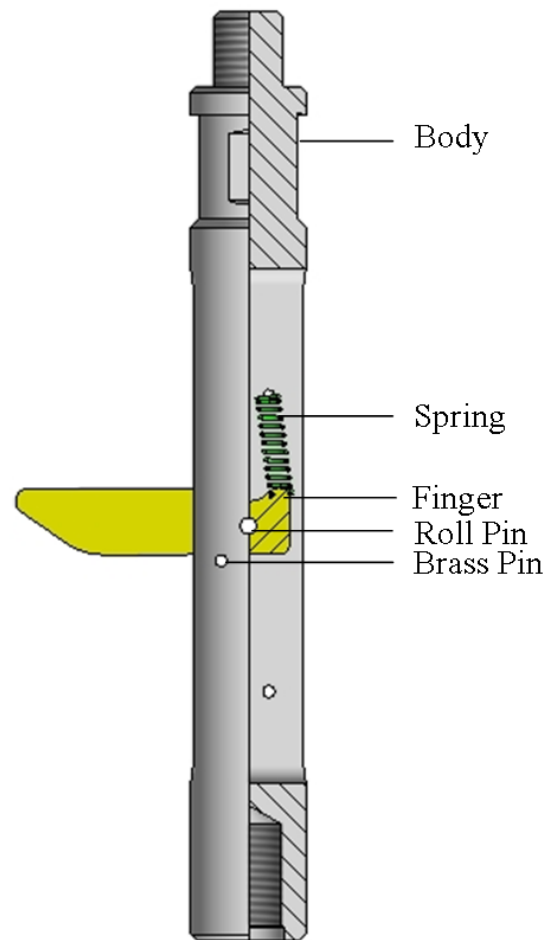

## TUBING END LOCATOR

### ASSEMBLY DESCRIPTION

The Tubing End Locator is used to determine the depth of the tubing using a spring-loaded Finger. The Finger catches the end of the tubing when pulled upward, registering as a reading on the weight indicator. Shear the pin by jarring upward on the assembly, and the Finger should retract back inside the tool so that retrieval is possible.





## TUBING END LOCATOR

SPECIFICATIONS			
	1.250	1.500	1.750
Fishneck	1.188	1.188	1.375
Connections	15/16"-10	15/16"-10	15/16"-10
Length	10.625	10.625	10.438
Shear Pin	3/16" X 1-1/4"	3/16" X 1-1/4"	3/16" X 1-3/4"

SPECIFICATIONS			
	2.000	2.500	3.000
Fishneck	1.375	1.375	1.375
Connections	15/16"-10	15/16"-10	15/16"-10
Length	10.438	10.438	10.438
Shear Pin	3/16" X 1-3/4"	3/16" X 1-3/4"	3/16" X 1-3/4"

All Specification Tables contain approximated dimensions and should be used for reference only.